

Client _____ Quantity _____
 Project _____ Position _____

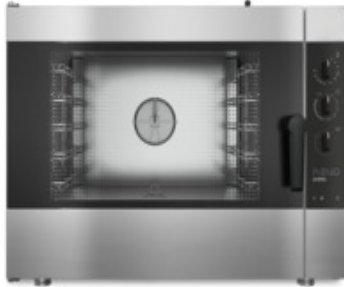

Pratika oven

Model: FCG051V

Cod: NP01052033001

Technical data

Number of pans:	5
Pans size (mm):	EN 600x400 - GN 1/1
Tray centre distance (mm):	74
Number of fans:	1
Fan speed:	2
Dimensions (mm):	905 x 845 x 750
Net weight (kg):	105
Volume (m3):	0,575
Chamber size (mm):	645 x 449 x 420
Electric power (kW):	0,4
Voltage (V):	220-240
Power supply (A):	2
Phases:	1N
Cable section (mmq):	3G1,5
Frequency (Hz):	50
Gas power (kW):	9,5
Total gas power (Kcal/h):	8169
Gas connection:	1/2"
Cold water connection:	3/4"
Cold water pressure (bar):	Max 5 bar
Softened water inlet:	3/4"
Drain size (mm):	40
Packing dimensions (mm):	955 x 900 x 921
Chamber size (mm):	645 x 449 x 420
Gross weight (kg):	120
Gross volume (m3):	0,800

Features

Oven type:	Convection
Control:	Electro-mechanic ovens
Steam:	Direct
Steam management:	Time management
Temperature range:	30°C - 280°C
Door:	Hinged door
Cooking chamber bottom:	Stainless steel cooking chamber
Range timer:	1' - 120'
Flue:	Manual input

Electro-mechanical gas convection ovens with humidifier. Capacity 5 trays Gn 1/1 or pastry 600x400. Cooking chamber with rounded corners, welded without visible welding. Adjustable height of the feet. Removable universal grid shelves (Gatronorm and Euronorm) with distance between trays of 74 mm (bakery grid shelves with a distance of 95 mm can be supplied on request). Door with wide glass surface equipped with air channel for the external glass ventilation, which further limits the temperature on the external surface. Pressure door-lock and re-opening through a side release; door handle in plastic material, highly resistant to shocks and temperatures. Silicone gasket inserted in the front of the chamber, with maximum seal capacity, avoiding temperature drops. Gutter for the collection of liquid, connected to the drain. Indirect heating by flame tubes and atmospheric burners. Timer from 1' to 120' (plus infinite position). Power-adjusting control humidifier. Temperature control in the cooking chamber from 50 °C to 280 °C. 2 speed fan. Double speed auto-reverse fans. Manual air-valve opening (motorized in the programmable models). Wide air flow channels of the chamber that allows a perfect cooking uniformity, both in conditions of scarce and full load. Folding opening of the internal glass. Control panel of all the functional parts placed on the left side of the oven. Safety thermostat in the cooking chamber to avoid dangerous high temperatures beyond 350°C. 2 speed fans. Water inlet for the humidifier control. Internal lighting positioned on the left side of the cooking chamber. Electric power 9,5Kwatt - 220-240V 50/60 Hz.

Technical draw

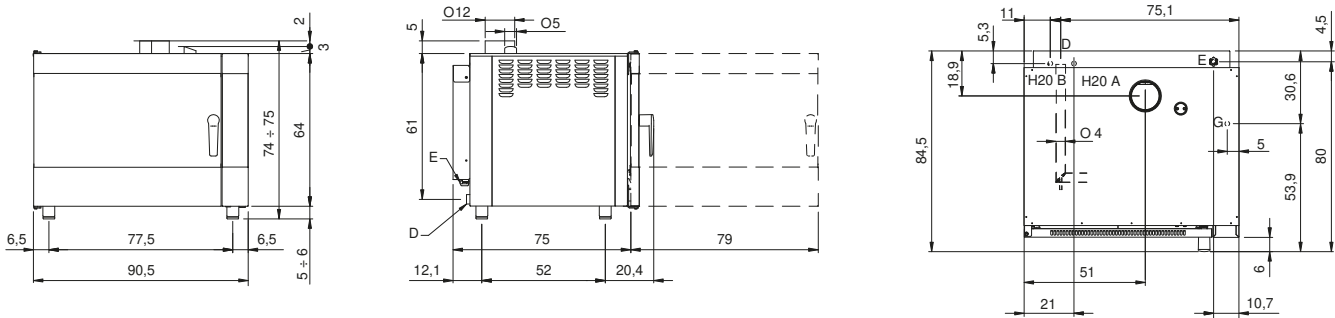

G: Gas connection

E: Electric connection

D: Drain for water

H2OA: Water inlet

H2OB: Softened water inlet